

Technical sheet :

MLT 635-140 V+ ST4



 **MANITOU**
HANDLING YOUR WORLD

Capacities		Metric
Max. capacity	Q	3500 kg
Max. lifting height	h3	6.08 m
Maximum outreach		3.20 m
Reach at max. height		0.60 m
Breakout force with bucket		5004 daN
Weight and dimensions		
Unladen weight (with forks)		7405 kg
Ground clearance	m4	0.41 m
Wheelbase	y	2.60 m
Overall length to carriage (with hitch)	l11	4.66 m
Front overhang		1.11 m
Overall width	b1	2.39 m
Overall cab width	b4	0.95 m
Overall height	h17	2.38 m
Tilt-down angle	a5	134 °
Tilt-up angle	a4	12 °
External turning radius (over tyres)	Wa1	3.77 m
Standard tires		Alliance - A580 - 460/70 R24 159A8
Drive wheels (front / rear)		2 / 2
Steering mode		Manicrab, 2 wheel steer, 4 wheel steer, Crab mode
Performances		
Lifting		7.10 s
Lowering		5.10 s
Extension		6 s
Retraction		4.50 s
Crowd		3 s
Dump		2.40 s
Engine		
Engine brand		Deutz
Engine norm		Stage IV
Engine model		TCD 3.6 l
Number of cylinders - Capacity of cylinders		4 - 3621 cm ³
Engine power (Hp / kW)		136 Hp / 100 kW
Max. torque / Engine rotation		500 Nm @1600 rpm
Drawbar pull (Laden)		6800 daN
Reversible fan		Standard
Engine cooling system		3 radiators water + intercooler + hydraulic oil
Transmission		
Transmission type		M-Vario Plus
Max. travel speed (may vary according to applicable regulations)		40 km/h
Differential lock		Limited slip differential on front axle
Parking brake		Manual
Service brake		Oil-immersed multi-discs on front & rear axles
Hydraulics		
Hydraulic pump type		Variable displacement pump
Hydraulic flow - Pressure		170 l/min - 270 bar
Flow sharing distributor		Standard
Tank capacities		
Hydraulic tank capacity		135 l
Fuel		120 l
Diesel Exhaust fluid (AdBlue® type)		10 l
Noise and vibration		
Noise at driving position (LpA) tested following NF EN 12053 norm		72 dB
Noise to environment (LwA)		105 dB
Vibration on hands/arms		2.50 m/s ²
Miscellaneous		
Tractor homologation		Tractor homologation
Cab certification		Cabin ROPS - FOPS level 2

Options / Finishing

S : Standard / O : Optional / - : Not available

	Classic	Premium	Elite
Lifting function			
Easy Connect System (ECS)	S	S	S
Electrovalve for 2 hydraulic functions (on boom head)	O	O	O
Hydraulic attachment locking	O	O	O
Intelligent hydraulics	O	O	S
Regenerative Hydraulics	O	S	S
Return pipe to hydraulic oil tank	O	O	O
Operator station			
Air conditioning with manual adjustment	O	S	-
Air suspension fabric seat - GRAMMER	O	S	-
Automatic air conditioning	O	O	S
Automatic wheel alignment	O	O	S
Bluetooth USB radio - With extra microphone - 100W	O	O	S
Bluetooth USB radio - With integrated microphone - 100W	O	S	-
Boom suspension - "Active CRC"	O	O	S
Exterior right electric rear-view mirror with de-icing	O	O	S
Extra front wiper	O	S	S
Harmony screen - 5 in.	S	S	-
Lateral wiper	S	S	S
Low frequency air suspension cloth-covered seat with heating	O	O	O
Low frequency air suspension fabric seat - GRAMMER	-	O	-
Mechanical cloth-covered seat (GRAMMER)	S	-	-
Tuner car radio - 50W	S	-	-
Vision screen - 7 in.	O	O	S
Motorization/Power			
Continuous flow hydraulics	O	O	S
Hand throttle	S	S	S
Self cleaning air prefilter	S	S	S
Secondary functions			
1 pair of pre-fitted Double Action rear hydraulic couplers	O	O	O
Additional fuel tank (25 l)	O	O	O
Automatic rotating towing hitch on counterweight	O	O	O
Hydraulic pick-up hitch	O	O	O
Hydraulic trailer brake	S	S	S
Ladder hitch with choice of hooks	O	O	O
Manual rotating towing hitch	S	S	S
Lighting			
Boom Work Lights (on fixed part) (x2)	O	O	O
Front and rear LED work lights on cab (x4 : 2 front + 2 rear)	O	S	S
Front and rear work lights on cab (x4)	S	-	-
LED + (4 additional work lights)	O	O	O
Security			
Audio warning on reverse	O	O	O

MLT 635-140 V+ ST4 - Dimensional drawing

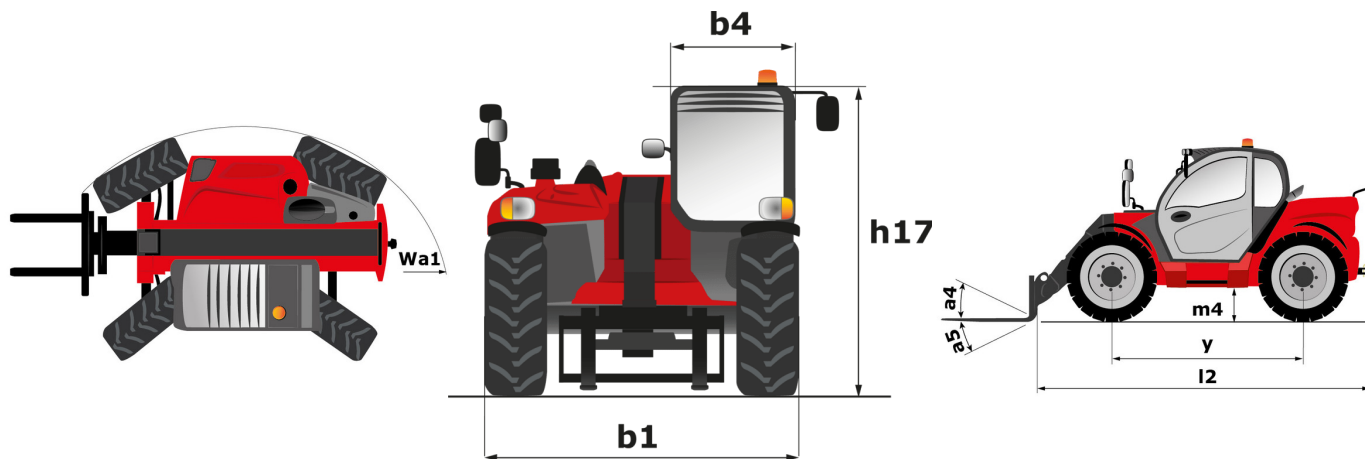



Head Office

B.P. 249 - 430 rue de l'Aubinière

44150 Ancenis Cedex - France

Tel: +33 (0)2 40 09 10 11 - Fax: +33 (0)2 40 09 10 97

www.manitou.com



This publication provides a description of the configuration versions and options for Manitou products, which may differ for equipment. The equipment presented in this brochure may be part of a series, as an option, or it may not be available, depending on the versions. Manitou reserves the right, at any time and without notice, to amend the specifications described and represented. The specifications provided do not bind the manufacturer. For more details, please contact your Manitou agent. This is not a contractually binding document. The presentation of the products is not contractually binding. List of specifications non-exhaustive. The logos as well as the visual identity of the company are owned by Manitou and cannot be used without authorisation. All rights reserved. The photos and diagrams contained in this brochure are only provided for consultation and information purposes.

MANITOU BF SA - Limited company with board of directors - Share capital: 39,668,399 euros - 857 802 508 RCS Nantes